













# ***MUELLER RECORD***



**DECEMBER • 1952**

# MUELLER

## Quality Waterworks Brass Goods

Corporation Stops	Curb Stops	Copper Couplings
 H-15000	 H-15175	 H-15405
 H-15010	 H-15200	 H-15425
 H-15020	 H-15275	 H-15450
 H-8185	 H-15300	 H-15460

**M**UELLER CO. manufactures a wide variety of equipment especially designed for the Water Works Industry. This includes a full line of distribution equipment and specialties. Nearly a century of experience has proved that you can depend on any product that bears the Mueller name.

**MUELLER CO.**

*Dependable Since 1857*

MAIN OFFICE & FACTORY DECATUR, ILLINOIS

JOHN A. MURPHY

# MUELLER RECORD

Published  
at Decatur, Illinois, by  
**MUELLER CO.**  
MANUFACTURERS OF WATER AND GAS DISTRIBUTION AND SERVICE PRODUCTS

MAIN FACTORY AND OFFICE  
Decatur, Illinois

PACIFIC COAST FACTORY  
Los Angeles, Calif.

CHATTANOOGA FACTORY  
(Hydrant and Valve Division)  
Chattanooga, Tenn.

DEPENDABLE  
SINCE

**1857**

CANADIAN FACTORY  
MUELLER, LTD.  
Sarnia, Ontario

BRANCHES  
New York, San Francisco

DECEMBER • 1952

Vol. XXXVIII

No. 5

HERMAN E. JACKSON, Editor

## CONTENTS

Just Between Us.....	1
Kalamazoo Exposes The Underground.....	2
LubOseal Gas Meter Stop.....	4
No-Blo Exhibit Tours Country.....	6
Mueller Equipment Goes To College.....	8
Canadians Have Interesting Sport.....	10
Reader Establishes Laboratory.....	12
Thought of the Month.....	12
Two Men Added To Sales Staff.....	13
Liverlip and Leo.....	14
The Puzzle Box.....	15
Nutshell Novels.....	17
Off The Record.....	18
Our Cover Picture.....	20

Member Industrial Editors Association of Chicago  
and International Council of Industrial Editors

Printed in the U.S.A.



## *Just Between Us...*

### WHAT'S THE HURRY?

**I**T SEEMS TO ME that we Americans are rushing along at a man-killing pace. Frequently I see a certain milkman who illustrates what I mean. He hops from his milk wagon, runs up to the house to leave milk then runs back to the wagon. He is always going on a run—from house to house—until his route is covered. He must be exhausted by the time he get back to the dairy. I wonder what his hurry is.

When a man I know is going somewhere, he dashes out to the car, jumps in, and hurriedly starts the engine. He doesn't wait for the engine to warm up. Instead, he jams his foot down on the accelerator and the car lurches forward in a jack rabbit start—tires squalling! If he ever thought about it, he might realize that he was not doing his automobile any good. Everywhere he goes, if only to the nearby grocer, he drives like that. What can be his hurry?

How many people do you know who sit down to a meal and literally swallow it whole? They are cramming food into their mouths when the previous mouthful has not yet been properly chewed. They polish off a full meal in 15 or 20

*(Continued on page 20)*



# Kalamazoo Exposes

**T**HE AVERAGE CITIZEN knows just two things about a water system: 1. To get water, you turn a faucet. 2. To keep on getting it, you pay your water bill.

In the interest of better public relations, the City Utilities of Kalamazoo, Michigan, recently showed to approximately 35,000 people all of the workings of a modern water system. By means of an attractive and dramatic display they demonstrated the facts of life of

water, starting with the pumping of it from the well, and carrying through to its ultimate use by the consumer.

The general idea of this project originated with Mr. Robert D. Strumpfer, Public Relations Director of the City Utilities. The City officials liked the idea well enough to authorize the rental of booth space at the Kalamazoo Builders Home Show, a popular annual exposition which features home construction, outfitting and decoration. The officials





# The Underground . . .

(Water system that is.)

also made available funds to secure material for the display.

Mr. Strumpfer then went to work with the Water Department for the actual planning and construction of the display. Albert Sabo, Water Department Supt., Irving Hicks, Ass't., and Abram Dedoes, Construction Supt., huddled over plans, and deciding on layout, called on the talents of their departmental employees for carpentry and cabinet making, piping, plumbing, construction of scale models, and decoration. The final result would be a credit to any commercial producer of displays, for it was accurate, realistic, and complete.

The typical "well" was a large glass jar with stratae of real gravel taken from actual test borings. The pump mounted over the well was a small working model of the type actually used by the City. Real water moved through a "treatment plant" and bubbled through a glass tube "main" which led to a residential area.

In front of one of the homes was an

open ditch with main exposed, and a toy water crew was represented as just completing a service to the house. Their equipment: trucks, bulldozer, trencher, were all to scale, obtained from the local 5 and 10c store. In the landscaped yards were lifelike trees and shrubs, and a lawn was being sprinkled to illustrate one of the customer uses of water. To complete the water system display were miniature commercial buildings and a realistic elevated tank.

To point up details of operation and equipment there was a full size water meter made of clear plastic, a model fire hydrant and gate valve, a short section of 6" main with corporation stop installed, joined by short lengths of copper pipe to the curb stop, compression stop, and meter, all actual material in proper sequence.

Albert Sabo, Superintendent, suggested including in the display a new MUELLER B tapping machine. There was some debate as to whether or not

*(Continued on Page 17)*

# The Mueller LubOseal Gas Meter Stop

By Frank H. Mueller  
Engineering Vice-President, Mueller Co.

**T**HE CHANGE-OVER of gas distribution systems to natural gas at higher pressure has brought about entirely new practices in gas distribution work, and it has, also, materially changed the requirements for a satisfactory gas meter stop:

Tests indicate that gas leakage in the low and medium pressure range increases directly with the gauge pressure. Hence, a stop that was leaking an undetectable amount at 7 inches water column pressure may leak ten times that much at 2.5 p.s.i. Even though this might not be a dangerous leakage, it could easily result in service calls.

Since most stops when new would hold any distribution pressure now used, this actually means that a stop must maintain its original holding qualities much better than heretofore, and, in addition, should be provided with simple means of restoring its original holding qualities.

The use of higher pressure provides the possibility of dangerous pressure on the meter and household appliances in the event of failure of the pressure reducing valve. Higher pressure may, therefore, not only create a dangerous situation which was not possible with low pressure, but it, also, reduces the time in which the situation can be brought under control.

A meter stop is the first, and often the only emergency shut-off, and it should be readily operable with the commonest household tools. Moreover, it should be of a type that most everyone understands and knows how to operate. It should not require any extra operations to turn readily or to hold pressure. Maintenance of these qualities should be a function of the gas company.

Even with low pressure distribution, an occasional explosion resulted from a broken stop when an inexperienced

person attempted to operate the stop by turning the nut, loosening the nut and tapping the key loose, or tightening the nut. Higher pressure accentuates this danger and requires a stop which eliminates the necessity for such operations and prevents the creation of a hazardous condition even if they are attempted.

A review of these considerations would indicate the following meter stop requirements for medium and high pressure gas distribution:

1. The stop should not leak at its rated pressure in either the open or closed position, and it should retain its pressure tightness over a long period of time and many operations without any maintenance. It should never leak out the top or bottom whether maintained or not.

2. The stop should be easily operable with the ordinary household wrench and it should retain this ease of operation for a long period of time and many operations without any maintenance.

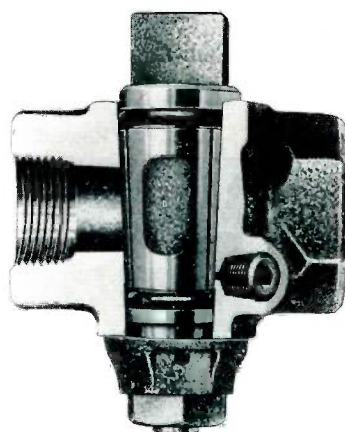

Cut-away view of LubOseal Gas Meter Stop. Note "O" Ring seals at top and bottom of key. See tapped hole whereby grease is fed to the machined grooves in key.

3. The stop should be provided with simple means for restoring the original holding and turning qualities.

4. The stop should be so constructed that an inexperienced or uninformed person can not create a dangerous situation in an honest attempt to operate the stop with any ordinary household tools.

5. The stop should be of a type with which everyone is familiar, and its ordinary operation should consist solely of a simple turning on or off.

6. The stop should be as low in price as is consistent with these essentials.

#### How LubOseal Stop Is Made

The new Mueller LubOseal gas meter stop was designed specifically to provide these qualities to a very high degree at a moderate cost. This stop is essentially an iron body, brass key, plug stop, a type of valve with which everyone who has operated a gas stove or other gas appliance is familiar. Operation consists of a ninety degree turn of the head, and the head clearly indicates the on and off positions. Like all ground key stops, the LubOseal does not expose the seating surfaces to the line fluid when in the open position, but in addition, the LubOseal is provided with false ports in the key and body which line up with the true body and key ports, respectively, in the off position, to prevent grit or dust from attaching itself to the seating surfaces when the stop is closed, and later damaging them. This, also, allows the gasway through the key to have flat sides, which reduces the pressure loss, makes the key much stronger for the same weight of metal, ensures seating contact at only those areas where it is useful, and reduces the contact area and turning torque.

A circumferential groove is machined in the top and the bottom of the key and these are connected by four machined vertical grooves at forty-five degrees with the ports. The vertical grooves are relatively narrow to reduce the generous lap by a minimum amount. The key is reduced in diameter above the top groove and the body is increased in diameter from a point just above the top of the bottom groove. This eliminates the production of shoulders when the key is lapped into the body. It, also, eliminates any contact of the key and body above and below the circumferential grooves.



Exterior view shows rugged construction of LubOseal stop.

#### Effective Sealing with "O" Rings

Synthetic rubber, gas resistant "O" rings are located in the top and bottom circumferential grooves. "O" rings are remarkable pressure sealing devices which have the amazing qualities of being simple, self-sealing, very effective, permanent, low in friction, and capable of sealing small clearances. They found their first great application in the hydraulic systems of airplanes during the last war and have since proved their effectiveness in many commercial products. It probably can be said that anyone who rides in a commercial airplane today trusts his life to an "O" ring.

The ability of the "O" rings to seal small clearances means that in the LubOseal stop, there is no rubbing contact above and below the "O" rings. The importance and novelty of this will be brought out later, but their effectiveness is well demonstrated by the fact that the LubOseal stop is the first ground key stop which the Mueller Co. has ever been able to pressure test to the destruction point of the casting. An ordinary stop leaks so badly out the top and bottom at 1200 to 1500 p.s.i.g., the pressure can not be raised any higher. A  $\frac{3}{4}$ " LubOseal body casting broke at 4800 p.s.i.g. without any leak whatsoever up to that point. It is believed that the "O" rings at the top and bottom of the LubOseal stop provide positive assurance against top and bottom leaks regardless of the condition of the stop.

The four vertical grooves which are

*(Continued on Page 14)*

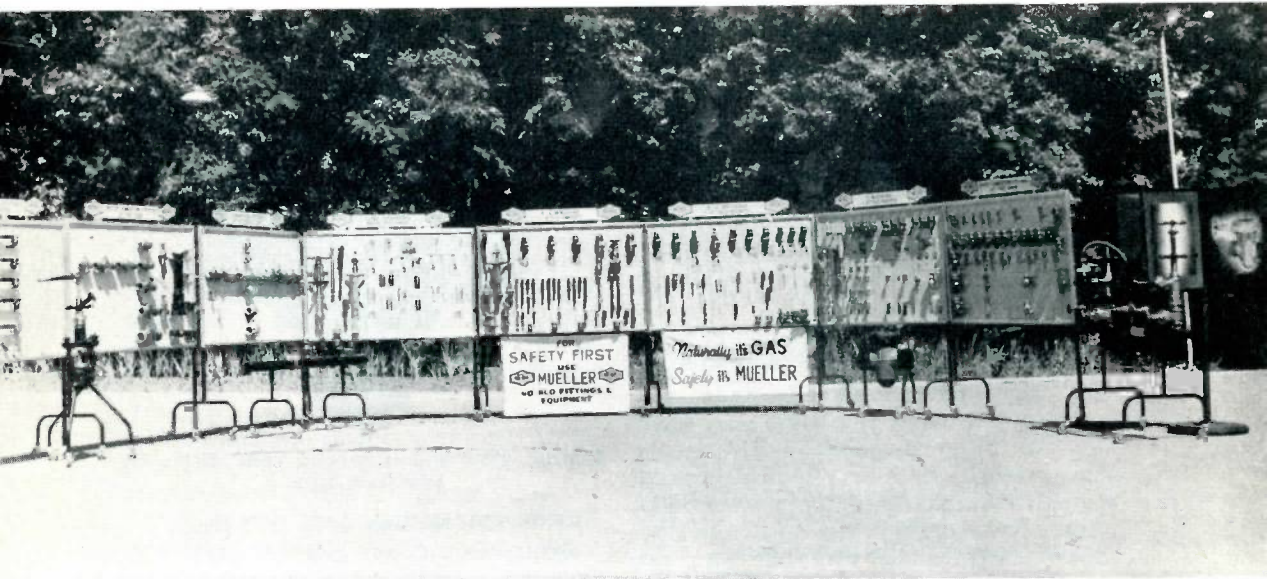

# No-Blo Exhibit Tours Country



**B**ECAUSE OF THE MANY problems presented by the introduction and use of natural gas at higher pressures, there has arisen a need for developing new and safer methods of handling gas under these conditions. The Mueller Co., a pioneer in this field, has kept pace with these demands. New and improved equipment and tools have been designed to insure safer and more positive methods of working on gas mains under any pressure. This line of gas equipment and fittings is marketed under the name "No-Blo".

In order to acquaint executives, engineers, and other key men in gas and

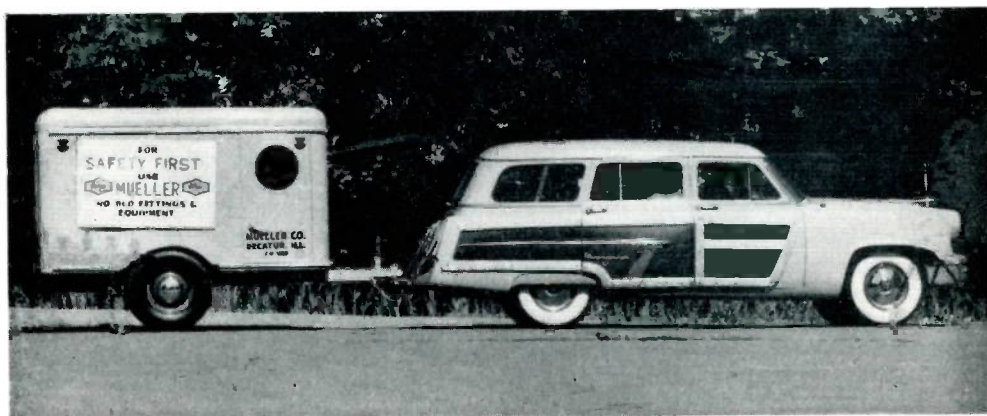



(At left) These panels and stands contain the equipment and fittings needed to properly demonstrate the safe handling of gas under pressure by the No-Blo method.

pipe line companies with these latest advances, Mueller Co. has created the Traveling No-Blo Exhibit. This exhibit, as may be seen from the accompanying photographs, is transported in a station wagon and trailer. The portable units, when set up, permit the adequate demonstration of the latest methods in use today. The traveling unit is staffed by Mr. Frank B. Miller, Gas Field Engineer, and his assistant, Mr. Francis X. Uhl.

The exhibit has been on the road since last August. At this writing it has been displayed and demonstrations have been made before audiences representing about 100 different gas companies. Between two and three thousand practical gas men have attended the demonstrations. Its reception has been extremely enthusiastic, and gas company officials everywhere have assured us that this educational program is worthwhile and well appreciated.

Mueller Co. intends to continue the appearance of this traveling No-Blo demonstration unit for some considerable time at different locations throughout the country so that all gas men interested in new construction methods will have an opportunity to observe and discuss them.

It is interesting to note that this means of contact with the gas industry has exposed the Mueller Co. to the very many problems confronting gas men. Some of these, in the normal course of affairs, might not have come to the attention of the company for some time. This has helped the Mueller Co. recognize and solve many problems of gas distribution much more promptly than under any other circumstance. As new problems develop, the company will, of course, take steps to meet them where possible.

(At left) This station wagon and trailer carry all the equipment shown at top of page. It will come to your area. Watch for it.

## Mueller Salesman Dies

**H**AROLD A. PROBST, 52, a Mueller Co. salesman in the New York territory for nearly 21 years, died November 30 in the Syracuse University Hospital, Syracuse, N. Y.

He was born in Paxton, Illinois, on June 23, 1900. His parents were Otto and Adamay Corneilus Probst. The family moved to Decatur when Harold was five years old.

He was married on November 2, 1924, in Decatur, to Thelma I. Johnson. Their only child, Richard, was accidentally killed in a dynamite explosion in 1943.

Probst, during World War I, enlisted in the air service signal corps. He served from 1917 to 1919. Following this he began working for the Mueller Co. on March 26, 1920. Eleven years later he was sent to New York to serve as assistant manager of the eastern sales office. Later he was given the New York state territory and went on the road. He had his headquarters in Syracuse.

He served continuously in this capacity as a salesman except for time out during World War II. In June, 1942, he enlisted in the Army as a first lieutenant and was sent to Italy with a military police unit. He was promoted to a captain and was discharged at the end of the war.

He leaves his wife, two sisters, and two brothers. Another sister preceded him in death. The funeral was held December 3, and the burial was in Decatur where he rests beside his son.

His successor to the New York area has not as yet been named.

■ ■ ■

### Season's Greetings

**W**E OF MUELLER CO. are pleased to take this opportunity to extend to our many friends and customers our sincerest wishes for a pleasant holiday season and the best of everything during 1953.

A sincere "thank you" to all you loyal readers who have written your editor offering suggestions and encouragement. We hope that you will continue your letters in 1953. Since we meet few of you personally it is the best way we have of knowing if our little magazine pleases you.

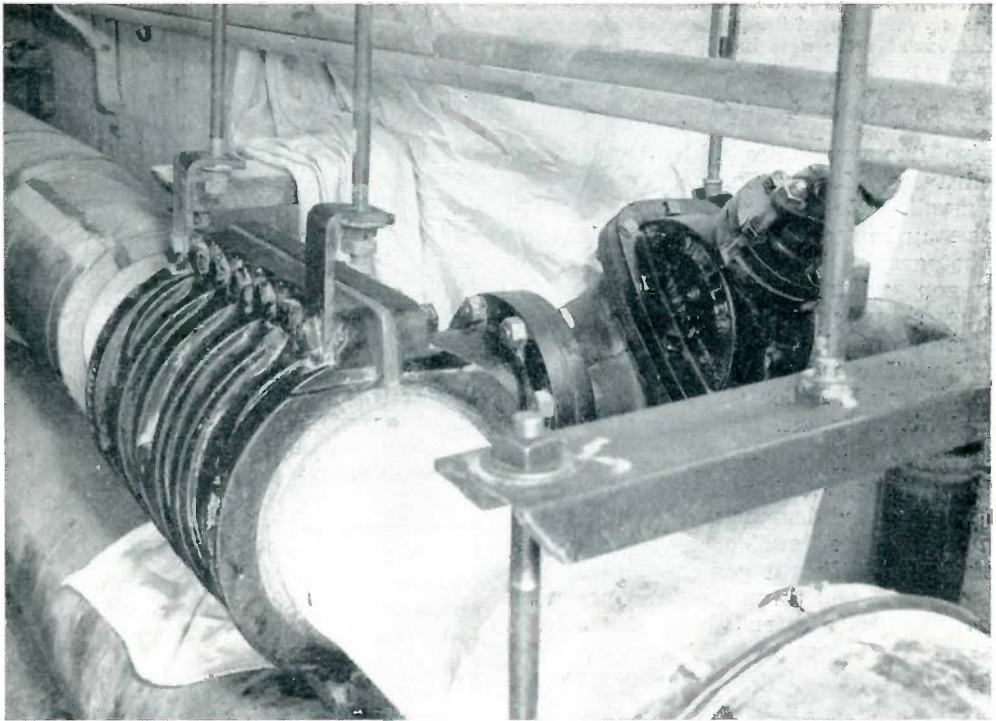

Installation in University of Arizona underground tunnel. A good view of the tapping sleeve is seen above. Below, a tapping valve is shown. Note the steel main outlet in the bell end of valve. Cloth in pictures was put there by photographer to help bring out the details of the installation.

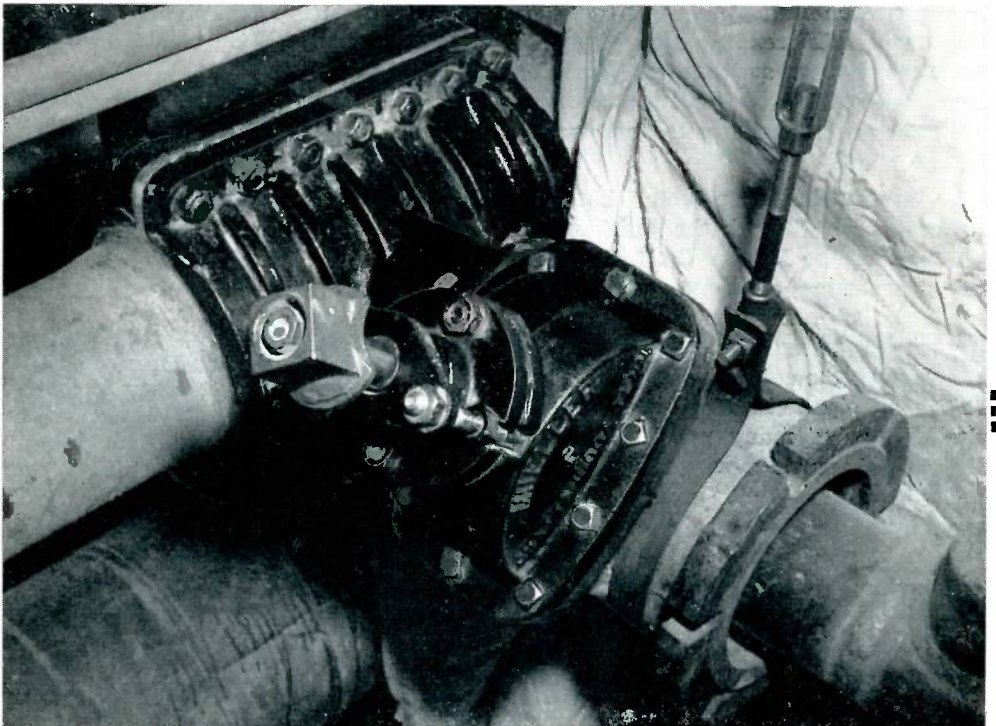

# Mueller Equipment Goes to College

**L**AST DECEMBER we ran a story about the new Y. M. C. A. here in Decatur. We featured the installation of a Mueller tapping sleeve and valve. Earlier we published a similar story when the J. C. Penney store was built. In both cases the installation was made by the S. E. McDaniel Co., Inc., of Decatur.

This summer we were pleasantly surprised to learn that the son of S. E. McDaniel, David S. McDaniel, is a plumbing and heating contractor in Tucson, Arizona. That the son was well coached in the business by his father is evidenced by the fact that the younger McDaniel is a loyal Mueller booster. He bought quantities of our chrome plumbing fittings before this line was discontinued, and he continues to use Mueller equipment and tools whenever he can.

To show that the Tucson branch of the McDaniel clan is on the ball as much as the father here in Decatur, we refer you to two installations in Tucson where Mueller tapping sleeves and valves and a Mueller drilling machine were used to make several cuts into a main under pressure.

The first job was the new Tucson Vocational High School building. The McDaniel firm did all the plumbing and heating for it. This was a \$150,000 contract and included the running of a six-

inch service line from a 12-inch city main. A Mueller 12x6 sleeve and valve were used. Unfortunately, the workman covered up the installation before our photographer could get there to make pictures of the operation. We do have a picture of the building.

Now it was "out of high school and on to college" for Mueller equipment. This time it was the University of Arizona where the new Business and Public Administration building was going up in Tucson. In Arizona, both heating and cooling work is done by plumbing contractors. The cooling of existing University buildings has been done by chilled water pumped from a central refrigeration plant on the grounds through an elaborate system of tunnels. In order to conserve the chilled water, two 8x6 sleeves and valves were installed on cement-asbestos pipe in a tunnel with little more than standing room. The outlet is steel pipe instead of the usual cast iron. This is not common practice, but we believe that the photograph well illustrates the skill of Mr. McDaniel and his staff.

When unusual problems or hard-to-get-at places turn up, it is nice for workmen to know that Mueller equipment can be depended upon to help them do the job right.

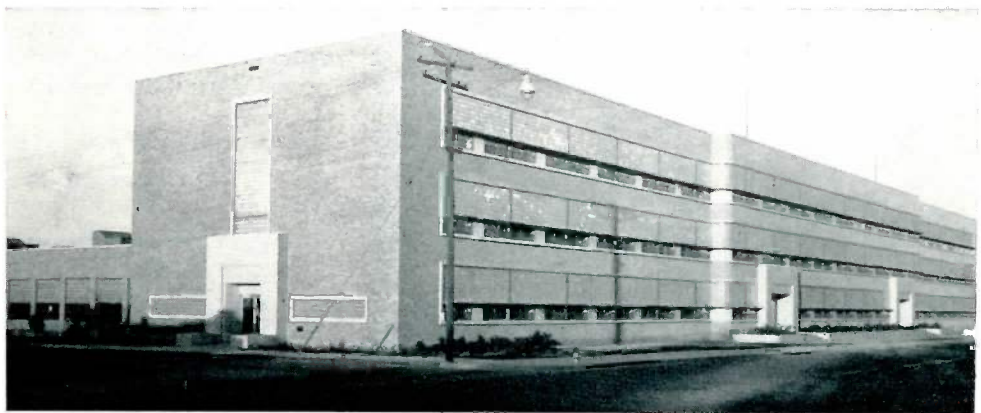

★ The new Tucson Vocational High School building where a Mueller 12" x 6" Sleeve and Valve were installed. ★

# Canadians



George Parker is receiving instructions from his Skip before delivering the stone. The two metal backs or toe holds are seen clearly here. The one in the open is for left-handed players. Parker, who is right-handed, has his foot on the other one.

UPON A RECENT VISIT to our Canadian factory in Sarnia, Ontario, we became acquainted with one of the oldest and most exciting ice sports—the time honored sport of curling. We found that a number of Mueller men are very active in this game. There is George Parker, president of Mueller, Ltd., R. M. Nicolson, vice-president in charge of sales, R. J. Skippon, vice-president in charge of factory, and J. Milne, secretary. J. F. Woodcock, our salesman in Montreal, also is a veteran of competitive play in eastern Canada. It ought to come natural to Mr. Milne as he was born in Scotland where the sport attained its greatest popularity.

Curling is a little pitching pennies at a crack in the sidewalk, only on a larger scale. It is a winter sport played on ice. At the end of the playing area is a target scratched in the ice, the center or button of this being 126 feet away. One observer called it shuffleboard on ice, but it is far from being as easy to play as that game.

The curling stone is round and thick and has a handle in the center to assist in controlling the direction of the slide. It is a little under one foot in diameter and weighs 40 pounds. We learned that after a man plays 10 or 12 ends or innings, and that means throwing two



The team poses for a picture. Left to right: J. Milne, George Parker, R. M. Nicolson, and R. J. Skippon. The brooms are an important part of the game.

Diagram to be drawn on the ice rules as 1

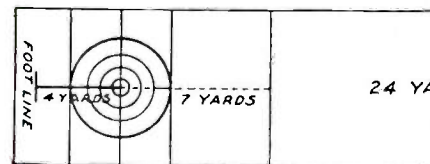

Back Score	Sweeping Score	Front Score	Hog Score	Compulsor
				Optional

# Have Interesting Sport



stones in each end, he can feel the effect of handling that heavy stone. When taking part in a bonspiel, which is the name for tournament play, each team goes through three rings or elimination games. The bonspiel is a real test of a player's physical stamina and control as that forty pound block of granite cannot be handled as easily as a basketball.

The game is popular in Canada. In Sarnia our four curling fans usually play on an artificial rink. This assures more uniform opportunities for play as the weather often interferes with natural ice rinks. The kind of surface on the ice has everything to do with the skill and scoring of the players. One of the amusing phases of the game to a newcomer is the sweeping. Under the direction of the skip or team captain a player may sweep the ice vigorously just ahead of the slow moving stone being played. The purpose is to remove the tiny particles of ice from the rink as these impede the forward movement of the stone. Sweeping can be very exhausting to a beginner as one must work fast. Good sweeping is very important as it can add as much as 15 feet to the distance ordinarily achieved by a good throw.

The accompanying diagram shows how the playing area is laid out. The three rings in the target or house are twelve, eight, and four feet in diameter. The hack lines are 138 feet apart.

and referred to throughout the  
THE RINK.

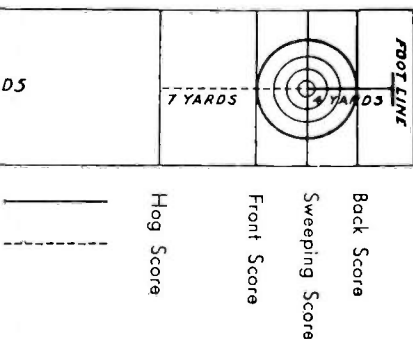

Parker delivers "on the broom." His left hand holds a broom for balance.

Unlike most sports, the player in curling is not on his own. The team captain directs all plays. He holds his broom on the button of the target to guide the curler as he slides his stone. He tells him how he wants the play made. This is similar to the way in which a baseball manager signals his batters and runners as to the moves he wants made.

Team members alternate in making the throws, and, as in pitching horse-shoes, the object is to knock your opponent's curling stones out of the house and put your stone or that of a fellow curler on the button. That is quite an art as the ice is slick and the stones are

*(Continued on Page 13)*

Milne and Skippon sweep the stone home on Skip Parker's instructions while Nicolson watches.



# Reader Establishes Radiesthetic Locator Research Laboratory

**I**N PREVIOUS ISSUES we have kept our readers informed of developments in the use of "pipe dowzers"—first mentioned in last December's Mueller Record. Since then we have learned the scientific names connected with these rods. The pair of rods are correctly known as Dual Radiesthetic Locators. The whole science of divination by rods or wands, and this includes water witching, is known as Rhabdomancy. If you are able to use these locators, then you are properly a rhabdomantist or rhabdomancer. These words stem from the Greek word "rhabdos" which means a wand or magician's staff.

Perhaps we should say here that there are on the market a number of electronic or magnetic pipe locators. These are scientific instruments that operate on proved scientific principles. There is no guess work about them. They do locate pipe.

On the other hand there is nothing scientific at present about these dual radiesthetic locators. A man we recently talked with reported that he had made a set from two pieces of No. 9 wire. No tubes were used for handles; the bare wire was held in the hands and he was not able to grip the wire tightly enough to prevent the rods from turning when over the location of the buried pipe. Some people cannot work the rods, but for an unexplained reason the rods do move for others. There may be a yet undiscovered force that causes this phenomenon.

It is just that force which one reader in Rhode Island has set out to find, if possible. He is not a water works or gas man, and quite by accident came upon someone using the locators in an effort to find a buried pipe. He became completely fascinated by the demonstration. As he told us, he is not interested in finding pipe, but rather his chief interest is in locating the force which causes the rods to move. He has set up a proprietorship known as the Radiesthetic Locator Research Laboratory.

He has retained the services of some professional research men who will assist in the hunt for this force.

To help this project along he has asked for help from Mueller Record readers. If any of you have used dual locators or "pipe dowzers" of any kind and have had any success, or even a partial success, he wants to hear from you. Address your letters to:

**Radiesthetic Locator Research  
Laboratory**

**Elmwood Station**

**Providence 7, Rhode Island.**

**Attention: Mr. C. W. Haffenreffer**

Mr. Haffenreffer particularly wants to know the kind of rods used—the size, the length, kind of handles, and the material from which they are made. Describe how they are held, how the rods behave, type of soil (wet or dry), kind of foot-gear worn, how accurate they are, and the kind of pipe or other objects located. Make your letters complete. It will better aid the researchers.

If any results are obtained from these studies, we hope to be able to report to our readers what has been discovered. Mr. Haffenreffer plans to print a report of the progress made, and any reader who cooperates with him on this project will receive a copy if he so desires it. If you prefer, you may write for a questionnaire first and he will send it.

■ ■ ■

**THOUGHT OF THE MONTH:**

●

**More people would get ahead if  
they spent less time getting even.**

# Two Men Added To Sales Staff

In a continued effort to improve our service to our customers, the Sales Division has added two new men and a third is taking the lengthy training program required of all men going into the field.

The first is Robert J. Cope who will cover West Virginia. Mr. Cope has had



Robert J. Cope

a long record in sales and service. Following his graduation from Millikin University he was in the construction business for five years. Next he was district manager in Pittsburgh for a construction supply firm. In 1940 he returned to Decatur to accept the vice-presidency of a paper house. Eight years later he formed his own company and operated it successfully. He sold this in 1952. Mr. Cope is married and has two sons now seven and five and one-half years

of age. These boys will no doubt share their father's interest in hunting and fishing.

The second man, Warren Crawford, will work in the Houston, Texas, area. His home was in Atlanta, Georgia, where in 1935 he was industrial salesman for a nationally known supplier of water works brass goods. He has been with this firm ever since and was assistant manager when he left this year. He attended Georgia Tech and is a member



Warren Crawford

of the Georgia Engineering Society. Mr. Crawford served in the Air Corps during the last war, and was a pilot and an instructor in instrument flying. He is married and has two children, a boy and a girl.

---

## Canadian Sport

*(Continued from Page 11)*

polished on the bottom. Draw shots in which the stone travels in a curved line toward the target are of great help in this game.

Our men play just for the fun of it and for the exercise that they get. Because the company recognizes the fine sport that it is, Mueller, Ltd., gives a trophy to be awarded to one of the winning teams in the annual city-wide bonspiel for curling.

Mr. Woodcock goes in for competitive play. Last winter he was elected presi-

dent of the Caledonia Curling Club of Montreal, one of the oldest curling clubs in the country. Out of 28 competitions in which his rockmen took part last season they captured honors in four, were finalists in another, and semi-finalists in three more. They took two consolation prizes, and were semi-finalist in another consolation series. This is their best showing in ten years.

Curling is not limited to Canadians, however, for there are many curling clubs in the United States. The largest privately owned rink in the world is in Duluth, Minnesota, where teams compete all year under the sponsorship of the Duluth Curling Club.

## LubOseal Meter Stop

(Continued from Page 5)

accurately machined in the surface of the key line up with a small hole in the stop body when the key is in any off or on position. This hole has an outside termination in a  $\frac{1}{8}$ " standard iron pipe thread. This provides for the introduction of grease to the four vertical grooves, the circumferential grooves, and the "O" rings. Since the "O" rings are the extremities of the contact surfaces, we believe this is the first and only lubricated stop that permits the lubrication of one hundred per cent of the contact surfaces while the stop is assembled.

### Greasing Principle Explained

Taking advantage of this novel construction, LubOseal stops are assembled without grease which allows the stop to be tightened just to the point where metal to metal contact is obtained between the key and the body. This is the point of optimum adjustment. The specially designed "tamper-proof" washer is then drilled with a blind hole and pinned to a large boss on the bottom of the key. Except for minor adjustment obtainable by the spring in the pin, the stop is now permanently fixed at the

point of perfect adjustment and will remain substantially in this relationship regardless of what might be done thereafter with the nut.

The lubricating grooves are now filled by forcing grease into the tapped hole in the body. Sufficient pressure is used to completely fill the grooves, force the air past the unlubricated ground key surfaces, and to compress the "O" rings until they occupy a minimum space in the "O" ring grooves. As the stop is now turned, the "O" rings try to regain their original shape and in so doing keep pressure on the grease and help the vertical grooves to distribute a uniform grease film of just the proper thickness for easy turning, long life, and best pressure sealing qualities. When the "O" rings regain their normal shape, the contact point with the wall of the body moves inwardly into a region formally occupied by grease, so that the "O" ring contacts are greased in this process, also.

The function of the "O" rings for the storage of grease pressure is one of the reasons LubOseal stops have such a remarkable operating life without re-greasing. Although no positive provision is made to prevent the escape of this pressure when the vertical grooves are

(Continued on Page 16)





# THE PUZZLE BOX

If our previous puzzles haven't driven you nuts, this one will. We are indebted to Mr. George Coldewey, managing superintendent of the City Water, Light, and Power Department of Jacksonville, Illinois, for it.

## The Pile of Cocoanuts

Five sailors were shipwrecked on a desert island where the only food was coconuts. They worked all day and gathered a huge pile of nuts. It was late and they were tired, so they decided to divide the pile the next morning.

During the night one non-trusting sailor got up, divided the heap into five even piles, had one left over which he threw into the ocean, hid his own pile, and rescrumbled the other four piles.

During the balance of the night, each of the other four sailors individually arose and went through the same operation, each finding an extra nut and disposing of it in the same manner.

The next morning the five men went through with their original plan and divided the remaining pile five ways. This time it came out even with no extra coconuts.

How many coconuts were there left to divide in the morning?

## The Train Crew's Dilemma

Following the dispatcher's orders, two trains met at a certain switch. Both trains were the same length, but the switch was not long enough to accommodate either of them. The switch would just hold the cars without the engine. Each train must proceed to its original destination with each engine pulling its own cars. How did the trains pass?

To help solve the problem, draw a diagram of the main line and switch on a piece of paper. Break off the heads of two matches one-half inch from the end. Let these be the engines and the rest of each match be the cars.

## Box Puzzle

From Mr. Robert A. Pfile of Bryan, Texas, came several very good mathe-

matical puzzles. We print one of them in this issue.

It is desired to make an open top box of the greatest possible volume from a square piece of tin, whose side is 2 feet, by cutting equal squares out of the corners and then folding up the tin to form the sides. What should be the length of a side of the squares cut out?

## Answers to July Puzzles

The **One Line Puzzle** depends upon a trick. Fold the paper over once, away from you. Fold the top part back toward you. Draw your pencil along this second fold. (See sketch at left.) If done prop-

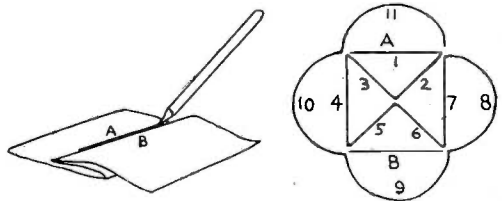

erly you will make both lines A and B with one stroke. Without lifting your pencil, continue as indicated at the right of sketch. You can complete the design without crossing or retracing any line and without lifting the pencil from the paper.

The answer to the **Near-Sighted Goose Puzzle** is 36 geese in the flock.

Send in your favorite puzzle with the answer. We will print as many as we have space for.

■ ■ ■

Little Felix stood before the cage, staring intently at the leopard inside. Then he turned to his mother and asked, "Is that the dotted lion that everybody wants Daddy to sign on?"

■ ■ ■

The upper crust is a bunch of crumbs held together by a lot of dough.

■ ■ ■

Then there was the cross-eyed professor who couldn't control his pupils.

■ ■ ■

Ignorance is when you don't know anything and someone finds it out.

■ ■ ■

Only fresh eggs get slapped in the pan.

## LubOseal Meter Stop

(Continued from Page 14)

passing the ports, the vertical grooves, being machined, are so proportioned that the pressure of the "O" rings moves the grease very slowly and all of the pressure is not dissipated until after a large number of operations.

On actual test, a number of LubOseal stops were in practically their original condition after 1,000 operations while many regular stops had begun to turn hard and leak after 50 operations. The LubOseal stop is not designed to be sealed by grease in grooves under pressure because this kind of a stop requires lubrication after every operation or at best very frequently. The lubricating grooves in the LubOseal stop are for the purpose of maintaining a proper grease film on the precision machined and lapped ground key surfaces so they will hold pressure and turn freely.

### Pressure Tight Seal Provided

The drilled hole in the body which connects with the grease grooves in any open or closed position is located below the port so there is always a ground key seal between the pressure and the grease port. The tapped outlet of the grease port is sealed with a hardened, socket head pipe plug. Normally there would be no leakage out the grease port if the pipe plug was not in place, but in any lubricated stop, there is some tendency for gas to find its way into the grease grooves and escape past the grease screw. The use of a pipe plug makes a pressure tight seal to prevent this. Moreover, the machined grooves reduced the chance of leakage and the grease capacity of the LubOseal stop to the point that once it has been filled, a very small amount of grease is needed to completely refill it.

If the LubOseal stop needs greasing as indicated by its turning quality, all that is required is to remove the pipe plug, fill the tapped hole with grease, and screw the pipe plug down to its seat again. Unlike the familiar lubricated stop, there is no grease screw to invite frequent or excessive greasing, and it is not nearly so likely that the socket head pipe plug, which requires an uncommon tool, would be removed.

The use of bulk grease instead of grease sticks is more economical and does not introduce unwanted material (the coating on grease sticks) into the stop. The greatly reduced grease capacity of the LubOseal stop as compared with an ordinary lubricated stop appreciably reduces the investment in grease alone.

### LubOseal Stop Turns Easily

The perfect adjustment and grease film obtained in the LubOseal stop is practically unobtainable in a stop which must be greased before it is assembled. As a result, LubOseal stops turn more easily and far more uniformly than stops manufactured previously. These stops will turn from  $\frac{1}{2}$  to  $\frac{1}{3}$  as hard as good regular stops when new, but the LubOseal will maintain this torque closely, whereas, a regular stop will turn progressively harder. LubOseal stops as assembled will require a torque in inch pounds of from 100 to 135 times the nominal size of the stop. This means that a 2 inch stop would require a maximum torque of 270 inch lbs., which is only 27 pounds on a ten inch wrench. Even turning this easily, they will hold 125 p.s.i.g.

As mentioned previously, the proper adjustment of this stop is sealed with a pin in a blind hole and a large boss on the bottom of the key. This pin is strong enough so that if a pipe wrench is placed on it (this is very difficult because of the design of the washer), the key can be twisted without shearing the pin. The stop performs satisfactorily even if the nut is removed. If the nut is tightened as much as possible, the threads will strip and the stop is still operable and in good shape although it will have a high turning torque. It is believed and has been demonstrated that a person can not produce a serious gas leakage out of the LubOseal stop with any tool commonly used to operate it even if he tries to do so.

### LubOseal Advantages Listed

A brief summary of the advantages of the LubOseal stop follows:

1. A simple type of stop with which most everyone is familiar and which requires no special knowledge or training to operate.
2. A precision fitted and lapped ground key stop designed to ensure contact on the generous sealing surfaces only.

3. A stop with an inherent low turning torque, held to close limits in manufacture, that does not change appreciably with time or use.

4. A stop which retains its superior pressure holding qualities without maintenance.

5. A stop with positive extra protection against leakage to the outside.

6. A stop which provides automatic maintenance of the proper grease film for an extended time.

7. Provision for easily restoring the original turning and holding qualities of the stop.

8. The only stop in which *all* of the rubbing surfaces can be lubricated with the grease system.

9. A sealed grease system to prevent leakage through the system itself.

10. A stop with the proper adjustment permanently fixed at the factory.

11. A truly "tamper-proof" stop with full provision for preventing a dangerous leak to be caused by anything that might be done in an effort to operate it.

12. A stop of moderate cost.

■ ■ ■

## Kalamazoo Exposes . . .

(Continued from Page 3)

the public would be interested in this rather complex specialized mechanism, so familiar to water men everywhere. It was finally decided to show the machine, and it attracted much attention from visitors who had "always wondered how you could cut a hole in the pipe without getting drowned".

During the five days of the show, the City Utilities exhibit was a high point of interest with a deluge of questions from visitors: "What makes water hard?" "Why is the water sometimes rusty?" "What causes water hammer?"

It is a certainty that most of these visitors got from the exhibit a greatly increased knowledge of their City Water Department, and were impressed by the amount of equipment, material, and manpower necessary to install and maintain their water system. They will get a little more of a thrill from the modern miracle of turning the faucet for their supply of pure, abundant water; and a better understanding of what they are paying for when they pay the water bill.

---

# NUTSHELL NOVELS

BY SKIPPER



## A Grave Mystery

*"Oh, I'm not the grave digger  
But I'm the grave digger's son;  
And I'll do the grave digging  
Till the grave digger comes."*

(The above song was written especially for this story by Professor Crackinck.)

Adam Watso, the great detective and renowned wonder of Lampoon, was standing on the corner rehearsing the events of the latest mystery in an effort to find a clue. For the last seven days someone had been at the Lampoon cemetery each night and had broken into the graves of the rich, stealing valuable jewelry. It could not be the grave digger for he was on a two-week vacation.

Watso was stumped for once. Not a trace of the thief could be found though someone had been seen going through the cemetery for several nights.

*"Oh I'm not the grave digger  
But I'm the grave digger's son;  
And I'll do the grave digging  
Till the grave digger comes."*

Adam started. From a recess in the post office building there came a voice singing that song. Turning around, he beheld a man who fitted the exact description of the person seen in the graveyard. With cautious steps Watso followed the man through the dark streets and through the cemetery to its opposite fence. After waiting until the man got to work with his shovel, Watso drew his gun, seized the man, and shouted, "Aha! I've got the grave robber!"

"Oh, but you are wrong!" replied the young man with a grave look. "I'm not the grave robber. I'm the grave digger's son out here digging up our potatoes."

The great detective fainted.

---

# Off the .. Record ..

## On a Toot

A tutor who tooted the flute  
Tried to teach two young tooters to toot.

Said the two to the tutor,  
"Is it easier to toot or  
To tutor two tooters to toot?"

■ ■ ■

"I took the recipe for this cake out of  
the cook book, dearest."

"Fine, honey. It never should have  
been in there anyway."

■ ■ ■

"Did you hear about the lightning bug  
that backed into the electric fan?"

"No, what happened?"

"He was delighted."

■ ■ ■

When you make up your mind that  
you can't take it with you, you will be  
happy to stay here with it.

■ ■ ■

"Your wife used to be terribly ner-  
vous, but now she is as cool as a cucum-  
ber. What cured her?"

"I took her to a smart doctor. He  
told her that her kind of nervousness  
was the normal sign of advancing age."



## Daffynitions

Shoulder strap: A piece of ribbon de-  
signed to keep an attraction from be-  
coming a sensation.

■ ■ ■

Slowly he regained consciousness. He  
looked up at the face above him. "Well,  
Doctor, was my operation a success?"

The face answered, "Sorry, old man.  
I'm Saint Peter."

■ ■ ■

## Mueller Minstrel Show

Mr. Bones: "Say, Mr. Interlocutor, my  
pet goat stuck his nose in my lawn-  
mower yesterday and cut it off."

Interlocutor: "Oh, that's too bad.  
How does he smell?"

Mr. Bones: "Awful! Hyak! Hyak!!  
Hyak!!!"

■ ■ ■

Boss: "Late again, Johnson. Don't  
you ever do anything on time?"

Johnson: "Yes, sir. I'm buying some  
furniture."

■ ■ ■

Salesman: "Say, boy, I want to see  
someone around here with a little au-  
thority."

Office Boy: "I'm your man. I have  
about as little as anyone. What is it  
you want?"

■ ■ ■

Teacher: "Muggsy, give me a sentence  
using the word 'bewitches'."

Muggsy (after deep thought): "Youse  
go on ahead. I'll bewitches in a minute."





### Famous Pads

Foot—, —lock. Corn—. Lily  
Shoulder—. That expense account.

■ ■ ■

The single girl walked into the office one morning and began passing out cigars and candy bars tied with blue ribbons. Her puzzled co-workers asked the occasion. Proudly she showed them the diamond on her left hand and announced, "It's a boy. Five feet nine and weighs 165 pounds."

■ ■ ■

According to unofficial sources, a new simplified income-tax form for next year contains only four lines:

1. What was your income for the year?
2. What were your expenses?
3. How much have you left?
4. Send it in.

■ ■ ■

First Guest: "This sure is a lousy party, isn't it?"

Second Guest: "Yes, it is. Very dull."

First: "What do you say we get our hats and blow?"

Second: "Sorry, old chap, I can't leave. I'm the host."

■ ■ ■

One woman to another: "Why don't you go to him in a perfectly straightforward way and lie about the whole thing?"

### Figures of Speech

I'm in a 10der mood 2day,  
And feel poetic 2;  
4 fun I'll just — off a line  
And send it off 2 U.  
I'm sorry U've been 6 O long;  
Don't B disconsol8,  
But bear your ills with 40 2de,  
And they won't seem so gr8.

■ ■ ■

Judge: "You haven't reached a verdict? Well, if you don't agree before six I'll have 12 suppers sent in to you."

Jury Foreman: "Please, your honor, just make it 11 suppers and a bale of hay."

■ ■ ■

Hold-up Man: "Stick 'em up, or else!"

Victim: "Or else what?"

Hold-up Man: "Quit trying to confuse me. This is my first job."

■ ■ ■

First Kid: "My grandfather plays the piano by ear."

Second Kid: "Well, if we must boast, —my grandfather fiddles with his beard."

■ ■ ■

Some people cause happiness wherever they go; others whenever they go.

■ ■ ■

Applicant for job: "I don't think I deserve a zero on this aptitude test."

Personnel Director: "Neither do I, but that's as low as I can go."

## *Just Between Us . . . .*

minutes. What is so important in life that these people cannot take time to eat properly?

A couple go for a walk in the park. They are just relaxing on a pleasant Sunday afternoon. They come to a place where the sidewalk turns at a right angle. So they cut the corner and wear off a little more grass. What is the need for this cutting of corners? They are not actually in any hurry for they are not going any place in particular.

This same urge to hurry possesses our nature lovers. This fall the beautiful autumn colors made Illinois scenery something to see. A friend invited us to go for a drive to see some of these gorgeous colors. We got in their car and headed for the open country. They roared down the highway at sixty or more. How come they were in such a hurry? We passed more scenery, but we never really saw it. A better plan would have been to take a side road and slow down to twenty-five miles an hour. (This would not be safe on a highway.) Then we could have enjoyed the splendor of nature at her best. Had anything of interest attracted us, we could have stopped and drank in all its fascinating beauty. Will you try this next time you are driving?

I used to push myself, too. If I heard a street car coming, I would run half a block or more at full speed in order to catch it. I finally cured myself of that some years ago. I was living at the YMCA and participated in their regular gym classes. One evening I fell and bruised myself and strained a muscle or ligament. Just to be sure it was nothing serious I visited a doctor. He looked me over. There were no bones broken. "What's the verdict, doctor?" I asked him.

"Nothing serious," he announced, "but you had better go slow for a week or two until nature mends the damage caused by that strain on your muscles."

"Well, I guess I'll have to quit running for street cars for awhile," I said.

He looked up, a bit surprised. "Why do you chase street cars anyway?" Actually, I could not give him a sensible

reason. "How old are you?" he asked.

"Twenty-three," I told him.

"How long do you expect to live?"

I studied a bit. "Oh, I would guess at least 50 more years."

The doctor looked down at the floor and tapped the tips of his fingers together. Then he leaned back in his swivel chair and looked straight at me. "Fifty years, eh? That's a long time." He paused a bit. "What's five minutes? Or ten,—or even fifteen? If you miss a street car isn't there always another one along pretty soon? What do those few minutes you lose mean in the fifty years you are going to live?"

I had never thought of it that way. Since then I have slowed down. I do not let trivialities upset me. If I cannot complete something today, it will still be there tomorrow. I never go at a hurrying pace unless there is a real need for it.

Doesn't it seem a bit stupid to tear along through life, rushing here and there, fraying nerves, boosting blood pressure up, and straining the heart? Sixty per cent of the beds in our hospitals are occupied by people who are there because of mental problems. Not crazy people, of course, but all with ulcers, hypertension, nervous breakdown, and other kindred ills. Why not determine now that you will not be one of them. The end comes soon enough to all of us. Why hurry it? Slow down. Will you?

■ ■ ■

## **OUR COVER PICTURE**

This month's cover is a photograph of Rush Creek in the June lake area of the High Sierras. It is an excellent composition with a good balance between the light and dark areas. It was made by Barbara Dunn of Los Angeles. Another of her fine photographs was used on our cover a little over a year ago. We surely do appreciate the generosity of Miss Dunn in letting us put it on our Mueller Record cover.

# MUELLER

*Quality Products*

**FOR THE WATER WORKS INDUSTRY**

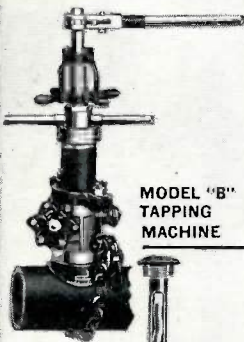

MODEL "B"  
TAPPING  
MACHINE

**PRECISION-MADE  
COPPER SERVICE PIPE  
COUPLINGS, CONNEC-  
TIONS, UNIONS**

H-15425



**WATER TAPPING MA-  
CHINES FOR MAKING  
CUTS UNDER PRESSURE**

**FIRE HYDRANTS  
ENGINEERED FOR  
DEPENDABILITY**



**EXTENSION SERVICE  
BOXES**

H-10314

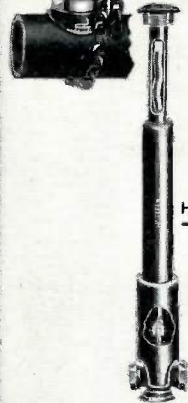

**GATE VALVES THAT  
SEAL PERFECTLY**

**CORPORATION STOPS  
FOR INSERTION UNDER  
PRESSURE**

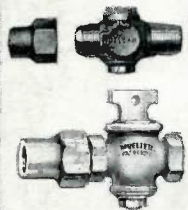

H-15000

**POSITIVE SHUTOFF  
GROUND KEY CURB  
STOPS**

H-15275

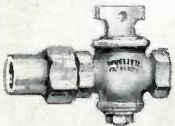

**MUELLER CO.**

*Dependable Since 1857*

MAIN OFFICE & FACTORY, DECATUR, ILLINOIS

# MUELLER®

## LubOseal®

(Pat. App'd. For)

### GAS METER STOP

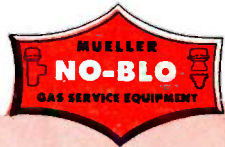
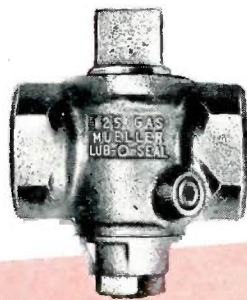
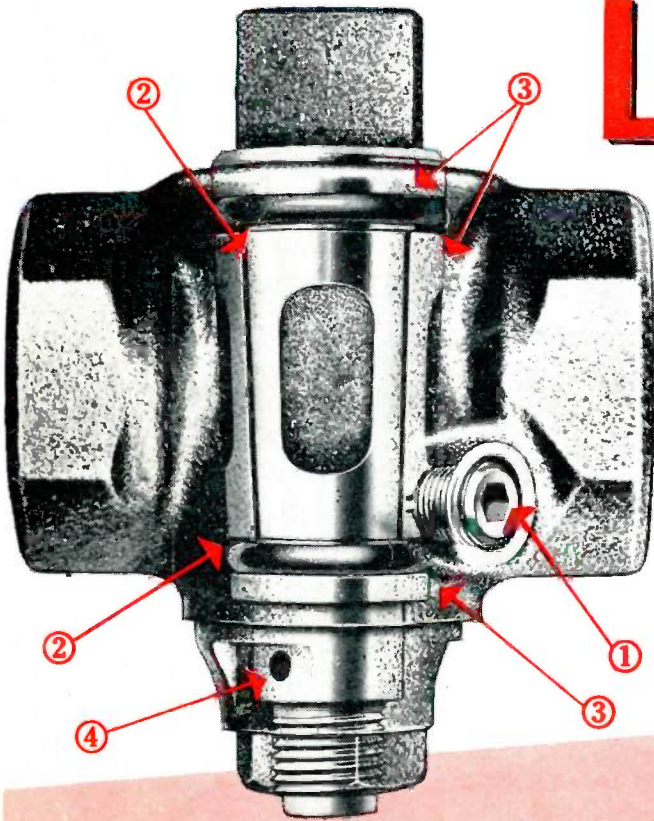

**1 TURNING AND HOLDING QUALITIES EASILY RESTORED:** Add grease to tapped hole, tighten screw. Lubricant is hydraulically forced throughout LubOseal Stop, forming a fine film over entire key surface.

**2 LESS SERVICE REQUIRED:**

As grease is forced into LubOseal, Neoprene "O" Rings are compressed, forming a grease reservoir. As stop is operated, "O" Rings slowly return to original positions, keeping all parts lubricated.

**3 LEAK PROOF:**

LubOseal Gas Meter Stops have been tested to destruction at pressures in excess of 4800 p.s.i.g. without any leak whatsoever up to this point. Precision machined key and body and "O" Rings provide perfect seal. Ordinary stops leaked badly at 1500 p.s.i.g.

**4 TAMPER-PROOF FOR SAFETY:**

LubOseal Stops are assembled dry, tightened to point of key to body contact, special washer and key boss are blind-pinned to each other, making this adjustment permanently factory fixed.

Write for free descriptive literature or call your Mueller Representative.

**MUELLER CO.**

Dependable Since 1857

MAIN OFFICE & FACTORY DECATUR, ILLINOIS